



**eVOQUA**  
WATER TECHNOLOGIES



# **VAF™ FILTRATION SYSTEMS**

**V-SERIES™ INDUSTRIAL AUTOMATIC SCREEN FILTERS**

**VAF™ brand V-Series™** automatic self-cleaning screen filters can remove suspended solids from 1500 to 10 micron rating. The V-Series™ filter bodies are manufactured in 316L stainless steel, made in the USA, and are competitively priced. The patented+ bi-directional drive design does not require electric motors, limit switches, gearboxes, or hydraulic pistons, thereby eliminating external shafts and seals. The cleaning cycle takes less than 15 seconds and does not interrupt the filtration process.

### MARKETS

- Industrial
- Municipal
- Oil and Gas
- Mining
- Irrigation

### APPLICATIONS

- Pre-Filtration to:
  - RO/UF Membrane
  - UV
  - Arsenic Removal
  - Bags/Cartridges
- Cooling Tower
  - Side Stream Systems
  - Basin Recirculation Systems
- Seawater
- Clams, Mollusks - Invasive Species
- Frac Water
- Well Water
- River Water
- Paper Mill
- Stormwater/Rainwater
- Pump Seal Protection
- Spray Nozzle Protection
- Process Water

And Many More

### BENEFITS

- 70% fewer moving parts (no electric motors, gearboxes, limit switches or pistons)
- Simpler controls
- Flush waste is less than 1% of system flow
- Greater cleaning efficiencies
- Lower maintenance requirements

### FEATURES

The patented+ design improves screen cleaning efficiencies resulting in:

- 100% screen cleaning with controlled suction nozzle rotation
- Priced competitively against all carbon steel body filters
- Individual flow rates from 7 to 2,274 m<sup>3</sup>/hr (30 to 10,000 gpm)
- Pre-assembled filtration systems to meet any flow demand
- Filtration 10 to 1500 micron rating
- Made in the USA

### NSF® CERTIFIED FILTERS

All models are available with NSF®-61-372 certification.



## GENERAL SPECIFICATIONS:

- Bi-directional Drive
- Max Pressure: 10 bar (150 psi)
- Min Pressure: 2 bar (30 psi)
- Max Temp: 80° C (176° F)
- Flush Cycle: 12 to 15 seconds
- Flow Range per Filter: 7 to 2,274 m<sup>3</sup>/hr  
(30 to 10,000 gpm)
- Flange Sizes: 3" to 40"
- Screen Options: 10 to 1500 micron on all models
- Manifold multiple units to increase flow ranges



Horizontal Design for ease of installation

## MATERIALS:

- Filter Body: 316L standard
- Screens: 316L SS Weave-wire
- Seals: Nitrile, Viton®, Silicone, EPDM

## Options:

- Filter Body: 2205 Duplex for Seawater
- High Pressure: 24 bar (350 psi)
- High Temperature: 99° C (210° F)
- Pressure vessel ASME, Section VIII, Div 1



Vertical Design for minimal footprint

MODEL NUMBER	SCREEN AREA		NOMINAL FLOW										FLUSH LINE	FLUSH VOLUME 15 SECONDS			
			25 micron		50 micron		100 micron		150 micron		200 micron			liters	gal		
	cm <sup>2</sup>	in <sup>2</sup>	m <sup>3</sup> /hr	gpm	m <sup>3</sup> /hr	gpm	m <sup>3</sup> /hr	gpm	m <sup>3</sup> /hr	gpm	m <sup>3</sup> /hr	gpm	m <sup>3</sup> /hr	gpm	in		
V-250	1445	224	30	134	41	181	63	276	73	320	82	360	1.5 NPT	30	8		
V-500	2890	448	61	269	82	363	125	551	148	640	164	720	1.5 NPT	57	15		
V-1000	5594	867	118	520	159	702	242	1066	277	1220	320	1410	2 NPT	57	15		
V-1500	8387	1300	177	780	239	1053	363	1599	420	1850	482	2120	2 NPT	87	23		
V-2000H	10942	1696	231	1018	312	1374	474	2086	553	2420	632	2780	2 NPT	125	33		
V-3 VERT	10942	1696	231	1018	312	1374	474	2086	553	2420	632	2780	3 flange	125	33		
V-3500	19742	3060	417	1836	563	2479	855	3764	906	3990	1139	5010	3 flange	167	44		
V-8000	43768	6784	924	4072	1248	5496	1896	8344	2212	9680	2528	11120	3 flange (x4)	500	132		

Other micron, larger flows, DIN flanges, BSP threads and customizing available upon request.



## HOW IT WORKS

Dirty water enters the filter through the inlet (1) and then passes through the coarse screen (2) from the outside in. It flows from the inside of the coarse screen to the inside of the fine screen and then passes through the fine screen (3) from the inside out. Dirt is collected on the inside surface of the fine screen. The clean filtered water then exits through the filter outlet (4).

As the dirt or cake builds up on the inside surface of the fine screen, the pressure drop across the screen increases. When the pressure drop (the DP or differential pressure) reaches a preset level 0.5 bar (7 psi), the filter controller starts a flush cycle by opening a flush valve on the flush outlet (5). This flush valve exhausts the flush chamber to atmosphere at "0" psi.

The flush outlet is connected to the flush chamber which is separated from the filtration chamber by a lower bulkhead. However, the dirt collector (7) (a hollow pipe with suction nozzles) extends through the partition (6), thus providing a "path" from the suction nozzles (8) through the water motor (9), into the flush chamber and out the flush outlet to atmosphere. The pressure around the suction nozzle is the pressure inside the filter and as water flows through the "nozzle orifice," it drops to "0" psi when it leaves the flush outlet. This creates an aggressive "suction" at the suction nozzle opening. The suction nozzle clearance at the fine screen is very small so the extreme low pressure at the nozzle opening creates a vacuum causing backflow to pull the dirt from the fine screen.

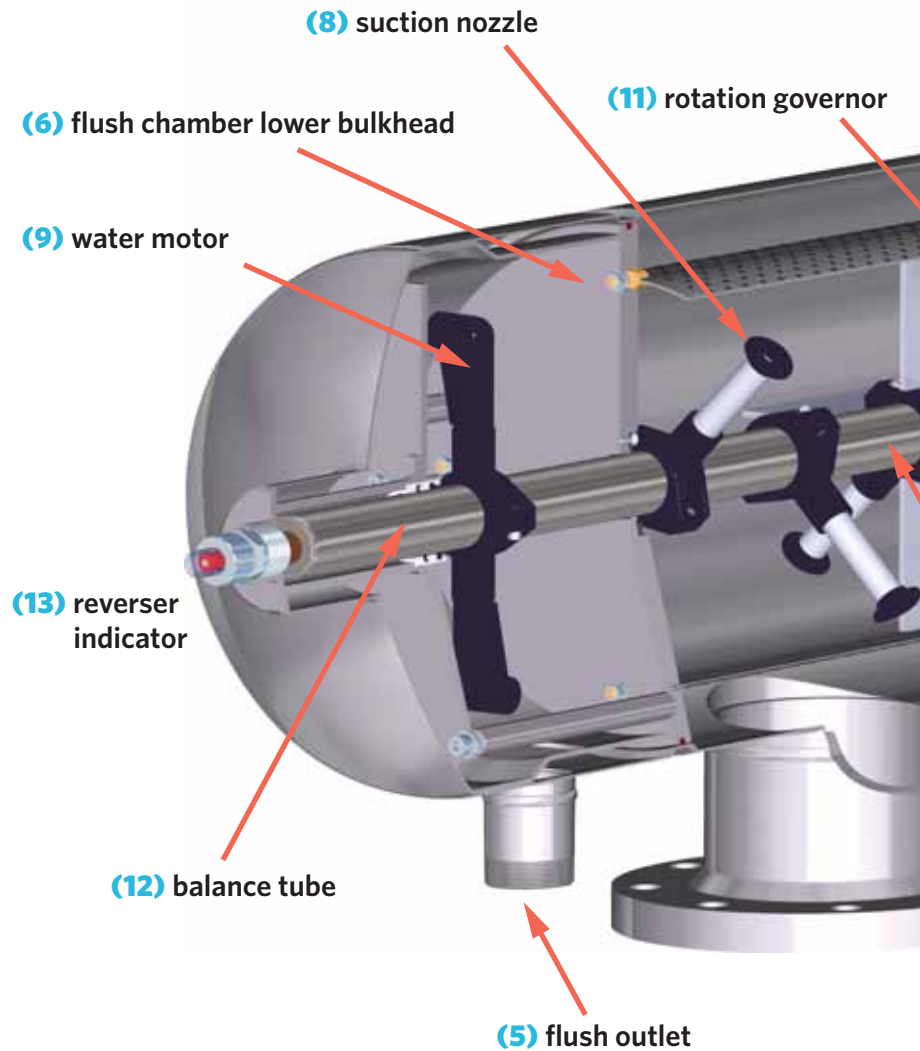

+Patented in some countries.

## DESIGN

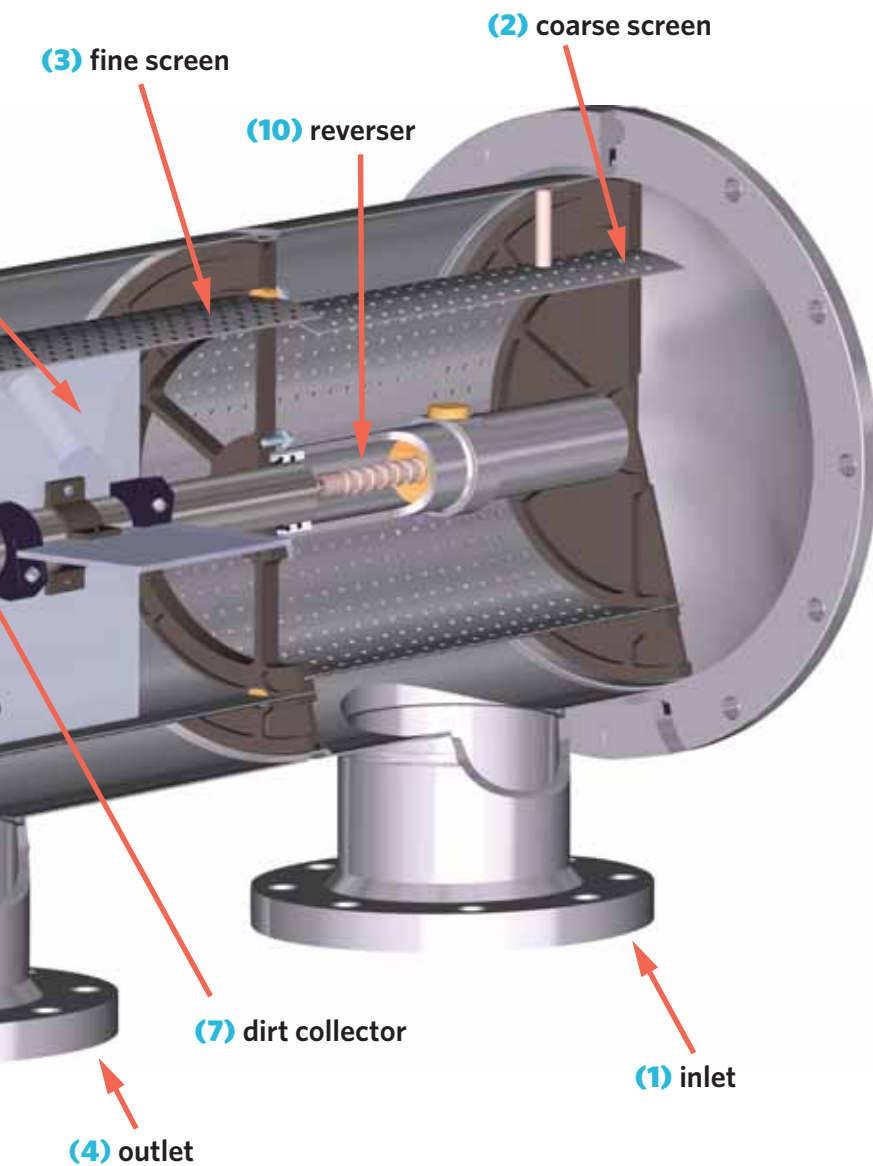

The water motor has opposite facing jets near its ends. Water jetting out of these openings (coming from the suction nozzles) creates a reaction force (like a pin wheel) which rotates the motor and the dirt collector. As the dirt collector rotates, each suction nozzle cleans a band on the fine screen.

As the dirt collector rotates, the reverser (10) (works like the level winder on a fishing reel) causes the water motor / dirt collector / suction nozzle assembly to move back and forth on a controlled path. This ensures proper overlap for 100% cleaning of the screen's inner surface. The rotation governor (11) helps control the rotation speed of the dirt collector assembly. The balance tube (12) helps balance the transverse pressure on the dirt collector. A magnet located on the end of the balance tube repels the reverser indicator (13) which provides visual indication of the dirt collector assembly movement. This indicates that the entire cleaning system is operating properly during the rinse cycle.

After a preset time, the flush valve closes and the flushing cycle is complete. Very little water is used for each flush; the filter continues to supply water to the system during the flush cycle.

Go to [www.vafusa.com](http://www.vafusa.com) to see the V-Series™ filter's simplicity in action.

**WORLDWIDE**

**SECONDARY WATER**  
Municipal Water Usage  
Utah

**RIVER FILTRATION**  
Fish Hatchery-Washington

**FRAC WATER**  
Oil & Gas-Colorado

**COOLING TOWER**  
Data Center-Colorado

**INTAKE WATER**  
Paper Plant-Canada

**MUNICIPAL INTAKE**  
OHIO

**RECYCLING WATER**  
Food Process-Colorado

**ZEBRA MUSSEL**  
Fish Hatchery - Kansas

**PRE-FILTRATION**  
Arsenic Removal Media  
Texas

**SEAWATER FILTRATION**  
Shrimp Farming-Mexico

**COOLING TOWER**  
Pharmaceutical-Puerto Rico

**COOLING TOWER**  
Petroleum-Mexico

**INTAKE WATER**  
Copper Mining-Peru

**POND WATER FILTRATION**  
Irrigation-Dominican Rep.

**TO SEE MORE PROJECTS,**

# APPLICATIONS



VISIT [www.vafusa.com](http://www.vafusa.com)

## ABOUT EVOQUA

Evoqua Water Technologies is the global leader in helping municipalities and industrial customers protect and improve the world's most fundamental natural resource: water. Evoqua has a more than 100-year heritage of innovation and industry firsts, market-leading expertise, and unmatched customer service, where it continues to transform water and wastewater. Its cost-effective and reliable treatment systems and services ensure uninterrupted quantity and quality of water, enable regulatory and environmental compliance, increase efficiency through water reuse, and prepare customers for next-generation demands.

Evoqua's unparalleled portfolio of proven brands, advanced technologies, mobile and emergency water supply solutions and service helps cities across the world provide and discharge clean water, and enable leisure and commercial industry to maximize productivity and profitability. For more information, visit [www.evoqua.com](http://www.evoqua.com).



5270 Marshall Street, Arvada, CO 80002 USA

Phone: +1 (303) 425 4242

Fax: +1 (303) 425 0112

[www.vafusa.com](http://www.vafusa.com)

[www.evoqua.com](http://www.evoqua.com)

VAF and V-Series are trademarks of Evoqua, its affiliates and subsidiaries in some countries. All other trademarks are those of their respective owners. May be covered by one or more US and foreign patents. Please contact us for further information.

All information presented herein is believed reliable and in accordance with accepted engineering practices. Evoqua makes no warranties as to the completeness of this information. Users are responsible for evaluating individual product suitability for specific applications. Evoqua assumes no liability whatsoever for any special, indirect or consequential damages arising from the sale, resale or misuse of its products.

© 2018 Evoqua Water Technologies LLC

Subject to change without notice

VAFV SERIES.BR.0118