

# Electric pump

## EL1204HHA/B/C

PUMP SPECIFICATIONS	Mod. A	Mod. B	Mod. C
Capacity [m <sup>3</sup> /h - (USGPM)]	100 - (440)	200 - (880)	300 - (1320)
Head [m - (ft)]	72 - (234)	60 - (195)	42.5 - (138)
Impeller diameter [mm - (in)]/type	435 - (17,4)/2 blades closed		
Flanged bore size [DN.../PN... - (in)]	DN100	DN150	DN200
	PN10 - (4)	PN10 - (6)	PN10 - (8)
Cross section diameter [mm - (in)]	35 - (1.4)		
Weight (without cable) [kg - (lbs)]	1100	1130	1160
	(2420)	(2486)	(2552)

### ELECTRIC MOTOR

Power [kW-HP]	90-120
Voltage [V]/Current [A]	460/141
Phases/Poles/Frequency [Hz]	3/4/60
Speed [RPM]	1750
Insulation class	H
Power cable 20m (IEC 60245- 4)	H07RN-F 4G35

### MATERIALS

Casing	Spheroidal cast iron EN-GJS-800-2 (EN 1563)
Motor housing	Cast iron EN-GJL-250 (EN 1561)
Wear parts	High chrome EN-GJN-HV600 (XCr18) (EN 12513)
Main shaft	High tensile steel 39NiCrMo3 (AISI 9840)

### SEALS / LUBRICANT

Motor side seals	1 mechanical seal (silicon carbide in oil bath)
Impeller side seals	1 mechanical seal (silicon carbide in oil bath) + 1 lip seal (BUNA) + 1 V-RING (TPU)
Oil type	ISO 320

### DIMENSIONS [mm - (in)]

H	W	D	F	H1	A	B	C
1450	902	774	600	1000	374	418	363
(58)	(36)	(31)	(24)	(40)	(15)	(16.7)	(14.5)

### PERFORMANCE CURVES

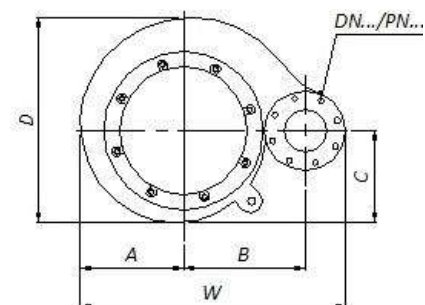
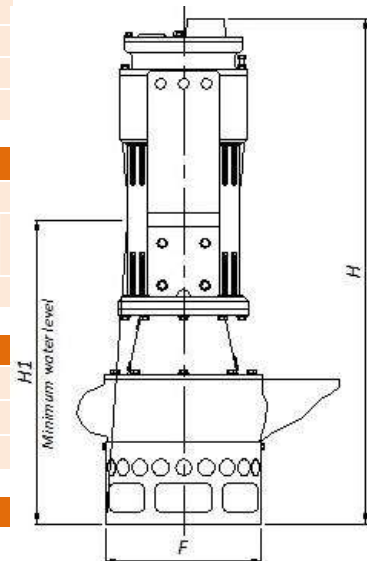
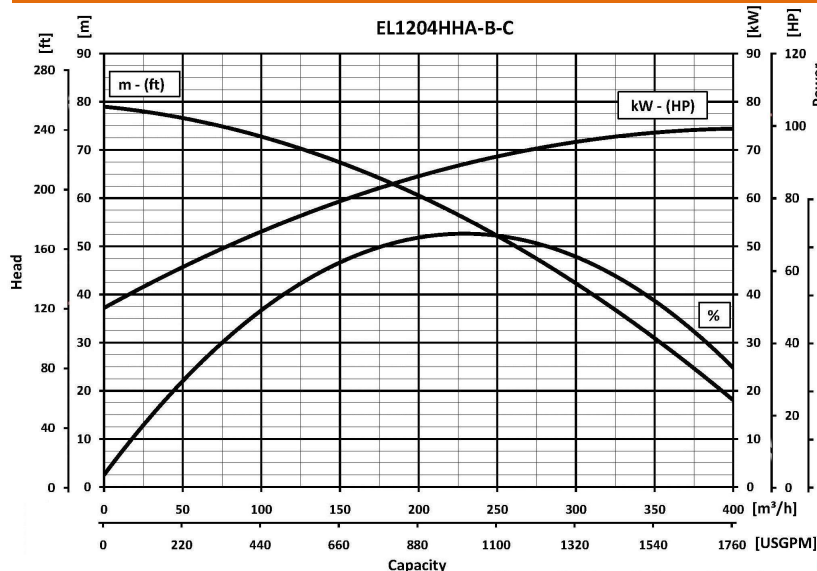

# EL1204HHA-B-C

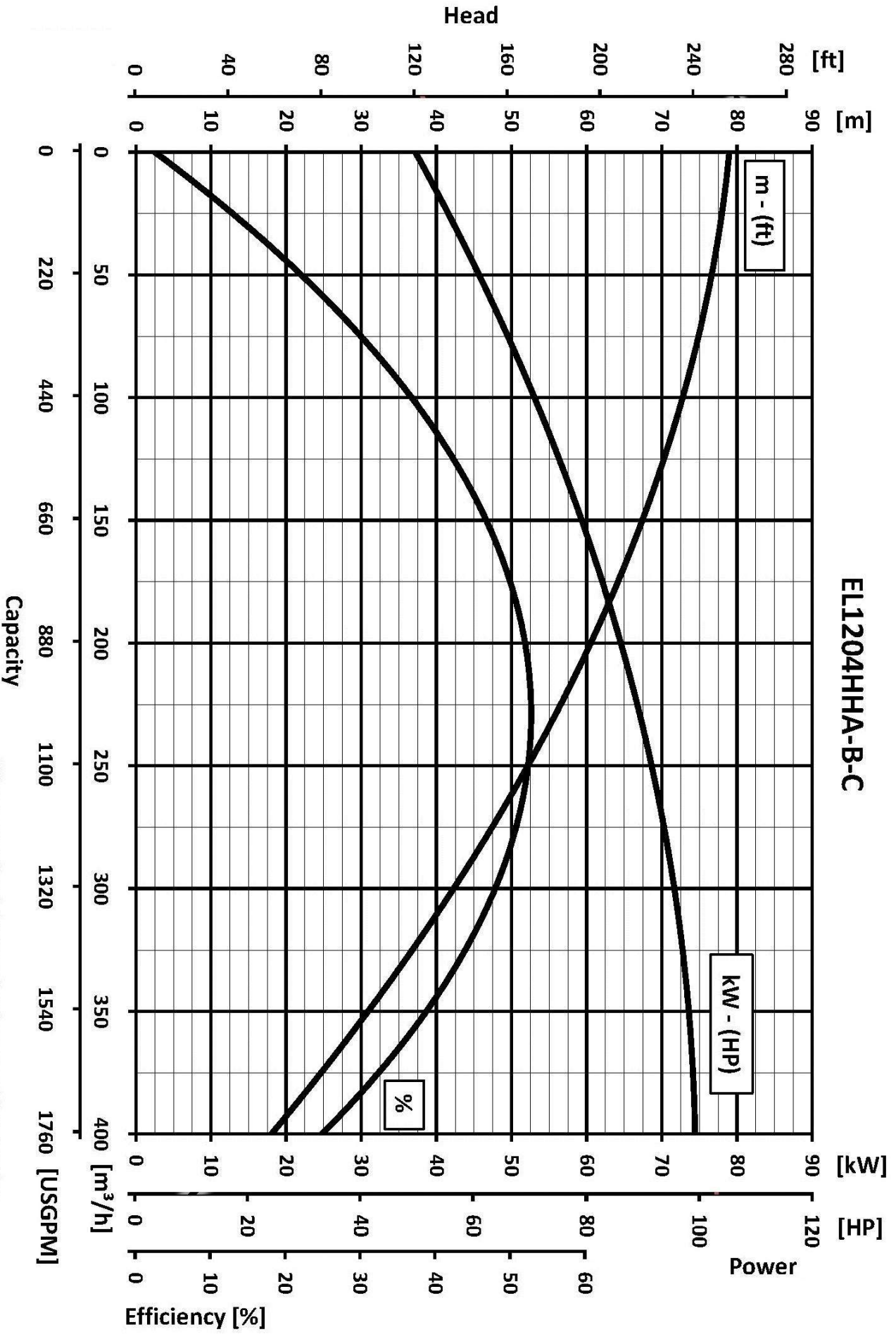

We reserve the right to make changes without notice